



»» MILLS GUARDS

# PFR 20

PRODUCT SHEET

Last update:  
04/13/2023

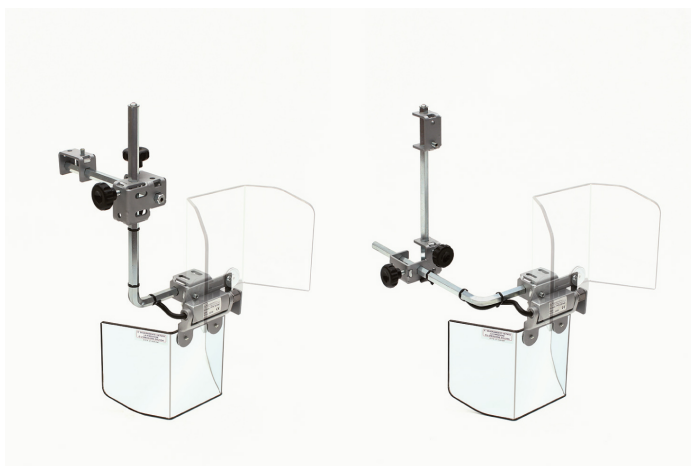

**FEATURES**

Protects the operator from direct contact with rotating parts of the vertical spindle and from the projection of shavings and lubricant-coolant. Shield equipped with innovative vertical "spring" opening system in the 60°- 120°- 180° positions. Supported by widely-adjustable hexagonal arms, reversible between themselves to make available various fixing configurations. The safety microswitch is integrated in the special hinge that supports the shield.

1. Anchorage stirrup - in pressed steel
2. Straight support arm - in hexagonal steel
3. Angular support arm - in hexagonal steel
4. "Cross" clamp for arm adjustment - in pressed steel
5. "Cross" clamp adjustment knobs
6. Shield support hinge with integrated microswitch - n. 2 NC contacts
7. Semi-hexagonal shield - in plastic shockproof and oil-resistant material

Exclusive item supported by adjustable hexagonal arms.

Equipped with vertical opening shield, with microswitch integrated in the rotation hinge.

CODE	A	B	C	KG
PFR 20/218	250	180	110	3,1
PFR 20/320	300	200	125	3,2

Our protections comply with the machinery directive 2006/43/CE

**CE**  
<https://www.tecnopiu.it/>