



»» **LATHE GUARDS**

PTO 02

PRODUCT SHEET

Last update:
04/13/2023

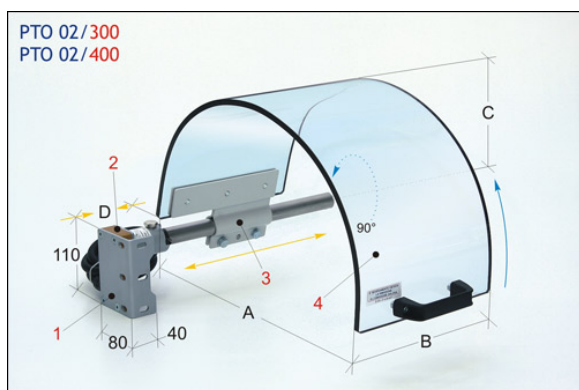

FEATURES

Protects the operator from direct contact with the upper part of the chuck lathe and from lubricant-coolant projection. Frontally and laterally attachable at the base. Equipped with semicircular monolithic shield, adjustable until near the machine head. Complete with safety microswitch.

1. Frontal and lateral anchorage stirrup
2. Safety microswitch main box - 90° rotation - n. 2 NC contacts
3. Adjustable shield connection clamp with support arm - in pressed steel
4. Monolithic shield - in thick plastic shockproof and oil-resistant material

The shield shape makes it ideal to be positioned until near the machine head. Equipped with monolithic shield in plastic material. Available in various dimensions.

CODE	A	B	C	D	KG.
PTO 02/300	300	200	200	0-200	3,0
PTO 02/400	400	220	250	0-190	4,9

Our protections comply with the machinery directive 2006/43/CE

