

»» **LATHE GUARDS**

PTO 10/M

PRODUCT SHEET

Last update:
04/13/2023

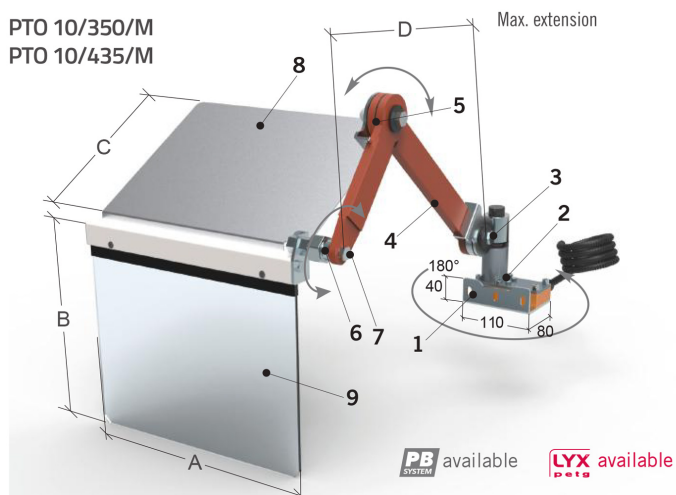

FEATURES

Protects the operator from direct contact with rotating components of the chuck and from the projection of shavings and lubricant-coolant. Attachable behind the longitudinal carriage. The shield, supported by articulated arm with one L. 190 mm. and one L. 325 mm. jointed elements, thanks to the ball socket joint, is completely adjustable and has an anti-shavings partition. Complete with safety microswitch. Available accessories: **PMG 60/185 - PBA 01/190 - PBA 01/325 - PBA 02/325.**

1. Frontal and lateral anchorage stirrup
2. Safety microswitch main box - 180° rotation - n. 2 NC contacts
3. Horizontal adjustment clamp
4. Articulated arms - in tubular steel
5. Rubbing articulation with friction disc
6. Ball and socket joint for shield orientation
1. Ball and socket joint release screws
8. Upper anti-shavings partition - in aluminium
9. Shield - in shockproof and oil resistant plastic material

Specific multi-adjustable item to be installed on the longitudinal carriage.

Combined with the chuck safety guard, allows an excellent protection of the operator.

CODE	A	B	C	D	KG
PTO 10/350/M	350	300	280	510	6,5
PTO 10/435/M	400	350	310	510	6,9

Our protections comply with the machinery directive 2006/43/CE

CE
<https://www.tecnopiu.it/>