

» **AUTOMATIC SANDING BELT HOLDER FOR LATHES**

SWH A01

PRODUCT SHEET

Last update:
04/12/2023

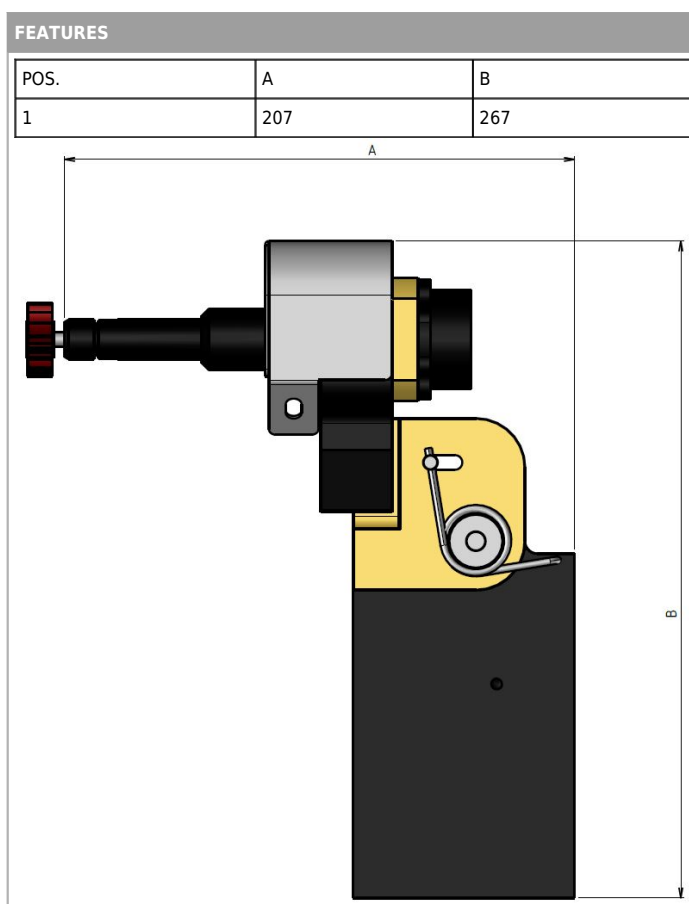
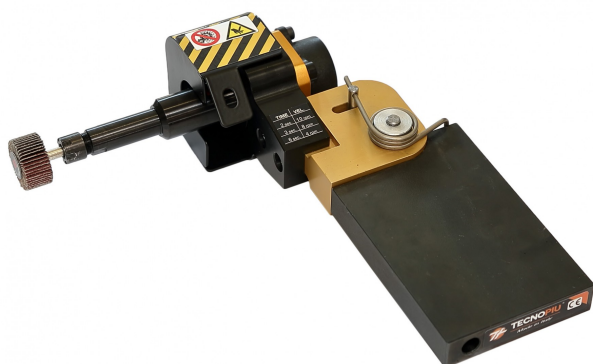

A new tool for sanding and refining the internal and frontal surfaces of bars for conventional lathes, with automatic movement of the abrasive tool, designed in accordance with ISO 23125: 2015 6.2.1p (prohibition to use hands for machining operations) which replaces, with maximum safety, the same dangerous operation usually performed manually. The device is fixed to the lathe toolcase turret and, thanks to the tension spring, the tool always adheres to the surface in an optimal way. The perfect efficiency of the device is guaranteed by an automatic sliding system (patented), which exploits the rotating movement of the workpiece. The device is provided with a tool holder nipper for 6 mm

Our protections comply with the machinery directive 2006/43/CE



diameter. Supplied with: no. 2 abrasive flaps for internal grinding and no. 1 pads for front grinding.

#	A	B
1	207	267

Our protections comply with the machinery directive 2006/43/CE

<https://www.tecnopiu.it/>



via Pio la Torre, 5 - 61010 Tavullia (PU) - Italy - VAT ID: 03657250407
Phone n°: +39 0721 476381 - Fax: +39 0721 476608 - Mail: info@tecnopiu.it